

**VESSEL**

***PORTABLE IMPACT WRENCH***  
***GT-3500GE-V-AU***

**Instruction Manual**

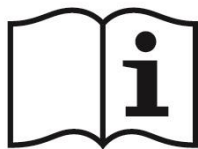

**VESSEL Co., Inc.**

## Preface

Thank you for purchasing the gasoline engine type impact wrench GT-3500GE – V - AU.

GT-3500GE-V-AU is a high-power two- stroke engine which can be used in places where power supply is not available. Please be sure to read this manual carefully and fully understand the contents before using the product, to ensure safe use

## Important Notice

The benefits to the consumer given by this warranty are in addition to other rights and remedies of the consumer under a law in relation to the goods or services to which this warranty relates. Our goods come with guarantees that cannot be excluded under the Australian consumer law. You are entitled to a replacement or refund for a major failure and for compensation for any reasonable foreseeable loss or damage. You are also entitled to have the goods repaired or replaced if the goods fail to be of acceptable quality and the failure does not amount to a major failure.

 Warning: Please read this manual after fully understanding the following terms

■ The safety precautions are listed below. In each case, important contents concerning safety are described, so be sure to observe them.

 **Warning** When it is assumed that the user may be killed or seriously injured if improperly handled

 **Caution** When it is assumed that there is a possibility that the user will be injured or property damaged when handling the product incorrectly.

■ Please keep this manual in a place where you can use it at any time, and read it repeatedly

■ If the warning label on the product is lost or soiled, promptly get it through our company or the dealer from which you purchased it, and put it correctly

■ When transferring or lending this product, be sure to attach this manual

If you have any questions about the product or the contents of this manual, please contact us or your dealer

 **Warning** ■ Be sure to read this manual carefully and fully understand the contents before using the product.

 **Warning** ■ Take care when handling fuel.

● Storage

Gasoline is highly flammable and must be handled and stored carefully. Gasoline should be stored in a specially approved container

● Handling or mixing gasoline at outdoor where there is no source of sparks or heat.

Gasoline is easily vaporized and highly ignitable.

● Do not smoke

Keep cigarettes away because of possible ignition.

● Refueling

• Always stop the engine when refueling.

• When removing the fuel tank cap, gasoline may blow out, so loosen it carefully.

• When refueling the fuel tank, do not fill the tank with fuel, but fill the tank about 10mm below the top of the tank .

• Allow the engine to cool down before refueling.

• Tighten the fuel cap securely after refueling.

● Before starting the engine

Wipe off any spilled fuel before starting the engine.

When starting the engine, be sure to start it at least 3m away from the refueling place.

● Never open the fuel tank cap immediately after stopping the engine.

● **The engine remains hot for a while after the engine stopped. Do not place the engine near flammable materials such as dried grass. There is a risk of fire.**

● Storage

Make fuel tank empty and dry before the storage.

Keep the machine and fuel away from heat and fire.

Make sure that vaporized fuel does not reach any source of fire or heat

 **Warning** ■ Work environment

- Use in an environment where ventilation is ensured.

This product emits exhaust gas. There is a risk of suffocation so use it outdoors or in a well-ventilated environment.

- Do not use where there is a risk of explosion

This machine uses gasoline as fuel. Never use the product where there is a danger of ignition or explosion.

### ⚠ Warning

#### ■ Clothes during work

- Please work with proper clothes

Do not wear necklace or large clothes. Also cover your long hair with a hat so that it does not get in the tool.

- Use work protection equipment.

To protect the human body, be sure to use helmets, protective glasses, earplugs, dust masks, anti-vibration gloves, safety shoes, and other work protective equipment according to the work

### ⚠ Warning

#### ■ When using an impact wrench

- Keep hands and cloths away from moving parts

It is extremely dangerous during use. Do not bring your hands or cloths near any moving parts.

- **Keep the grips clean of oil, fuel and dirt.**

- Working in an unreasonable posture is dangerous.

Please work in a stable working posture by securely holding the impact wrench and responding to sudden movements.

- Avoid unexpected starting.

When starting the engine, make sure that the throttle lever is in the stop position. When carrying, do not put your hand on the throttle lever

- Make sure when hang.

When hanging the unit with a balancer, etc., check that the hooks are securely attached. Check the hooks regularly and replace it if necessary.

- Do not contact with electricity

This machine is not insulated from contact with electricity. Use with care not to contact electricity.

- If you feel any abnormality, stop using it immediately

If you feel any abnormality during use, stop using immediately and request inspection and repair.

### ⚠ Warning

#### ■ Others

- Do not use for any purpose other than specified.

Never use it for any purpose other than the specified one, as it may cause an accident.

- Do not remodel

Never use the product after remodeling it, as it may cause an accident

- Do not remove parts.

Never remove the attached parts or screws, as doing so may cause an accident

- If a danger is expected, stop the engine immediately.

Be sure to stop the engine when changing accessory tools or when other dangers are anticipated.

### ⚠ Caution

#### ■ Basic precautions when using

- Please work carefully

When you are careless, insane or tired, it may cause injuries or accidents.

- Keep away from anyone other than authorized people.

Do not bring anyone other than the personnel involved in the work place. Especially children are dangerous.

- Do not use it with violence.

Violence may cause damage or failure, so use it carefully.

- Be careful of the direction of exhaust

Be careful of the exhaust direction so that the exhaust does not directly hit your eyes or ears, as it may cause an accident or illness.

- Exhaust gases are extremely hot. Keep flammable materials, people and animals away 1m from the exhaust direction of muffler.

Do not block exhaust gases with any objects. There is a risk of catching fire and getting burn.

- This machine will be hot.

This product gets hot when used so please do not touch anything other than the handle and the operation unit.

- Please handle carefully.

Rough handling may cause an accident or a malfunction. Do not throw or drop it to give an impact.

- Be careful not to drop the machine when working at heights.

To prevent accidents caused by dropping, be sure to take safety measures such as using safety wires when working in high places.

- Please pay attention to the noise regulations

Regarding noise, there are regulations specified by laws and ordinances of each area. It must be used below the regulation value. If necessary, provide sound insulation walls

- Please take a break at a regular interval.

Prolonged continuous work may cause illness, so take a break at a regular interval. If you feel any abnormality such as pain, stop using it immediately, consult a doctor, and follow the instructions.

**⚠ Caution**

- Maintenance, inspection and repair

- Be sure to check before use.

Before use, be sure to check for loose screws and damage to components. Not only may it cause performance degradation or failure, but it can also be dangerous.

- Be sure to perform maintenance and inspection

For safe and efficient work, do not neglect maintenance and inspection.

- Please contact us or our authorized (designated) service factory for repair

For repairs, please contact us or our authorized (designated) service factory through your dealer or agency. Please note that we will not be responsible of any accidents or malfunctions caused by the customer's own actions.

**Before use**





- After unpacking, check that the accessories are correctly installed.
- Be sure to read the instruction manual and do not operate the product or change the accessory until you fully understand it.
- Always keep this instruction at hand. If you have any questions, be sure to check the instruction manual.
- Please keep the instruction manual carefully so as not to lose it. If you lose it, please order a new one again.

**Use**



• This product is a tool designed and developed for the purpose of "the bolts and nuts tightening and loosening using the engine as a power source". Do not use it for a different purpose such as:

- \* Use above or below the abilities indicated in the specifications.
- \* Modify or weld products.
- \* Use other fuel than mixed gasoline.
- \* Use in water or in a flammable atmosphere.
- \* Use for other unexpected uses.

**Safety related symbols**

	Indicates a danger warning, or caution.
	Before using the product, read the instruction manual carefully and understand the contents before using it
	This product uses mixed gasoline. Gasoline is highly flammable and please note that it is dangerous. Stop the engine before refueling. Keep heat and fire sources away from fuel
	This product generates exhaust gas when used The exhaust gas contains toxic components and is extremely dangerous. Do not use in poorly ventilated environment
	This product gets hot when used. To avoid the risk of burns, do not directly touch the hot parts or others, stick to the handle and lever.

CHAPTER 1 For safe use

	Please use safety glasses
	Please use earplugs.
	Vibration occurs.

CHAPTER2 Specifications

Sound Level	$L_{PA}$	[dB]	104.8
	$L_{WA}$	[dB]	115.8
Vibrations Level	Without damper	[m/s <sup>2</sup> ]	18.7
	With damper	[m/s <sup>2</sup> ]	14.7

\* Vibration value  $ahv$  = 3- axis composite value of frequency correction vibration acceleration execution value

Vessel Co., Inc. 〒537-0001  
Fukaekita 2 -chome, 17 -25, Higashinari ku, Osaka, Japan

Product name Portable impact wrench

Model name GT-3500GE-V

2006/42/EC (98/37/EC)

Vibration measurement standards: JIS B 7761-1  
JIS B 7761-3  
JIS B 7762-7

$$\text{Day vibration exposure } A(8) = ahv \times \sqrt{\frac{T}{8}} \quad (\text{m/s}^2)$$

T = Exposure time per day (actual usage time per day)

Noise measurement standards ISO15744

Engine	Type	2 -stroke, air-cooled
	Engine exhaust amount[cm <sup>3</sup> ]	41.5
	Idling speed[m <sup>-1</sup> ]	2500-3000
	Maximum engine output[kw] (ISO8893)	1.57
	Guaranteed engine output [kw] (ISO8893)	1.54
	Mixed gasoline	Unleaded gasoline: Two- stroke engine oil 25-50:1
	Fuel tank capacity[cm <sup>3</sup> ]	1000
	Carburetor type	Diaphragm
Spark plug	Type	BPMR8Y
	Electrode gap [ mm]	0.6-0.7
EMI	Test item	lawn mower
	identification	lawn mower CE420
	Serial No.	F00003
	Sample No.	1
	Sample receipt date	October 29, 2012
	Test specification	CISPR 12:2007+A1:2009
	Test date	October 30,2012
	Test results	PASS
	The value is smaller because the overall length is shorter than the lawnmower that performed this inspection.	
※CO <sub>2</sub> /g/kWh	1101	
Impact wrench	Square drive section (mm)	25.4
	Tightening torque (Nm)	Full throttle: 1700 Half throttle: 900
	Tip rotation speed (m <sup>-1</sup> )	1200
	Ability bolt diameter (mm)	32
	Weight (kg)	Without damper: 19.8 With damper: 21.6
	Dimensions (mm)	Length: 700 Height: 330 Width: 390
Accessories	Hex wrench (mm)	4mm 1pc. 5mm 1pc. 6mm 1pc.
	Plug wrench	1pc.
	Spanner (mm)	10-13 1pc.

 ※CO<sub>2</sub>

This CO<sub>2</sub> measurement is the test result for a fixed test cycle under laboratory conditions, is the (parent) engine that represents the engine type (engine family), and does not guarantee the performance of a particular engine

**⚠ Warning**

- Be sure to follow the instructions in the operation manual.
- The following use are prohibited.
  - \* Tip is not properly installed or is not the right size.
  - \* Working posture is unstable, cannot be held properly, and cannot be operated.
  - \* Slippery, unstable environment.
  - \* Use for purposes other than screws/bolts tightening and loosening.
  - \* Use when there is no modification or lack of parts.
  - \* Use fuel other than specified.
  - \* Use in an environment where there is a risk of fire or explosion.
  - \* Use in a poorly ventilated environment.
  - \* Use under conditions that exceed the usage load of this product. Etc...
- When not in use or when not present , remove fuel and store in an environment free from fire and heat.
- This product gets hot when used. To avoid the risk of burns, do not directly touch the hot parts.

**⚠ Warning**

- Exhaust gas

This product generates exhaust gas when used. The exhaust gas contains toxic components and is extremely dangerous. Do not use in poorly ventilated environment

**⚠ Warning**

- Protective equipment

Use protective equipment required to work such as safety glasses, ear plugs, dust-proof mask, helmet, safety shoes, and anti- vibration gloves. Work clothes should be of appropriate size, fasten buttons, zippers, belts, etc., and be careful not to get long hair caught in the mechanism.

**⚠ Caution**

- Recommended oil

Use 2 cycle engine oil for mixed gasoline.

Do not use water-cooled outboard motor 2 -stroke oil. This type does not include air-cooled 2 -stroke additives for engine and it may damage the engine.

Do not use automobile motor oil. This type does not include air-cooled 2 -stroke additives for engine and it may damage the engine.

**⚠ Caution**

- Recommended fuel type

Use clean, unleaded petrol with an octane rating of 85 or higher. Use of unleaded petrol results in fewer combustion chamber deposits and longer spark plug life. Use of premium grade fuel is not necessary or recommended.

IMPORTANT: Never use gasohol or alcohol blended fuels in this engine.

**⚠ Warning**

- Blended gasoline

The engine used for the GT-3500GE-V has a two- cycle design. Engine internal moving parts (crankshaft bearings, piston bearing, piston, cylinder wall contact portion, etc.) need 2 cycle engine oil for lubrication. Improper mixing ratio can damage the engine.

Petrol	Two-stroke oil	
	50:1	25:1
	ISO-L-EGC/EGD, JASO class FC/FD, or equivalent two-stroke oil	ISO-L-EGB, JASO class FB, or equivalent two-stroke oil
1 liter	20mL	40mL
2 liters	40mL	80mL
3 liters	100mL	200mL

✘ Do not mix gasoline in the tank. Prepare gasoline mixed in the correct ratio in advance and refuel.

- When mixing gasoline, use an approved container.
- Put a mark on the container so that it can be identified as mixed gasoline.
- Make sure the gasoline is evenly mixed before refueling and do not spill.

**⚠ Warning**

● Handling of fuel

- 1 Gasoline is highly flammable and must be handled and stored carefully. Gasoline should be stored in a specially approved container.
- 2 Handling or mixing gasoline at outdoor where there is no source of sparks or heat.
- 3 Keep cigarettes away because of possible ignition.
- 4 When refueling the fuel tank, do not fill the tank with fuel, but fill the tank about 10mm below the top of the tank.
- 5 Wipe off any spilled fuel before starting the engine.
- 6 Tighten the fuel cap securely after refueling.
- 7 When starting the engine, be sure to start it at least 3m away from the refueling place.
- 8 Never open the fuel tank cap immediately after stopping the engine.
- 9 When removing the fuel tank cap, gasoline may blow out, so loosen it carefully.
- 10 Allow the engine to cool before refueling.
- 11 Make fuel tank empty and dry before the storage.
- 12 Keep the machine and fuel away from heat and fire.

**=NOTE=**



**⚠ Caution**

How to operate the engine

● Before starting the engine

1. Please check whether there is any abnormal (damage, loose bolt, missing parts...)
2. Create the mix fuel-oil and fill the fuel tank according to the instruction manual.
3. Please put the unit on the ground.
4. Please keep people, children or animals away from the work area.

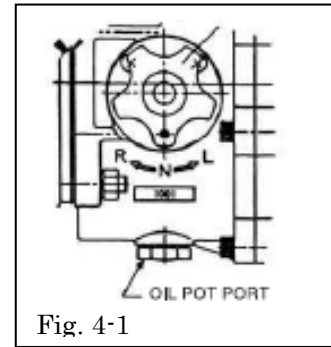

Fig. 4-1

**⚠ Caution**

Procedure to start the engine.

● Perform the following steps to properly start the engine.

1. Put the unit on a flat place.
2. Set the gear change lever to neutral. (Fig. 4-1)
3. Press the priming pump several times to send fuel to the carburetor and make sure that the fuel is no longer foamy.
4. Set Choke lever (Figure 4-3) position to "I/I".
5. Pull the start lever and press the lock button (Figure 4-2). By pressing the lock button, throttle is locked at half position. To unlock it, pull the lever again.
6. Pull the starter handle and start the engine.

- \* Do not pull the starter rope completely when pulling the starter handle. The rope may break and cause a malfunction.
7. When the engine starts, return the choke lever to the "I I" position, If the engine stops, start it again.
  8. If the engine does not start in step 7, restart from step 4.
  9. When the engine starts, return the throttle lever and let the engine idle for a few minutes to warm up.

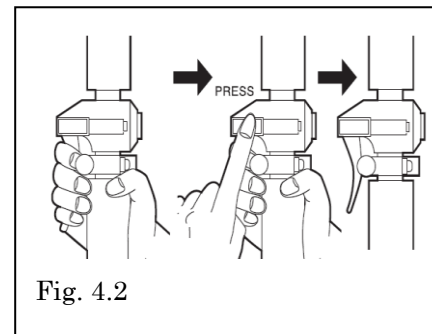

Fig. 4.2

**⚠ Caution**

● How to stop the engine.

- 1 Release your hands completely from the throttle lever.
- 2 Press the stop switch until the engine stops completely. (Fig. 4-3)

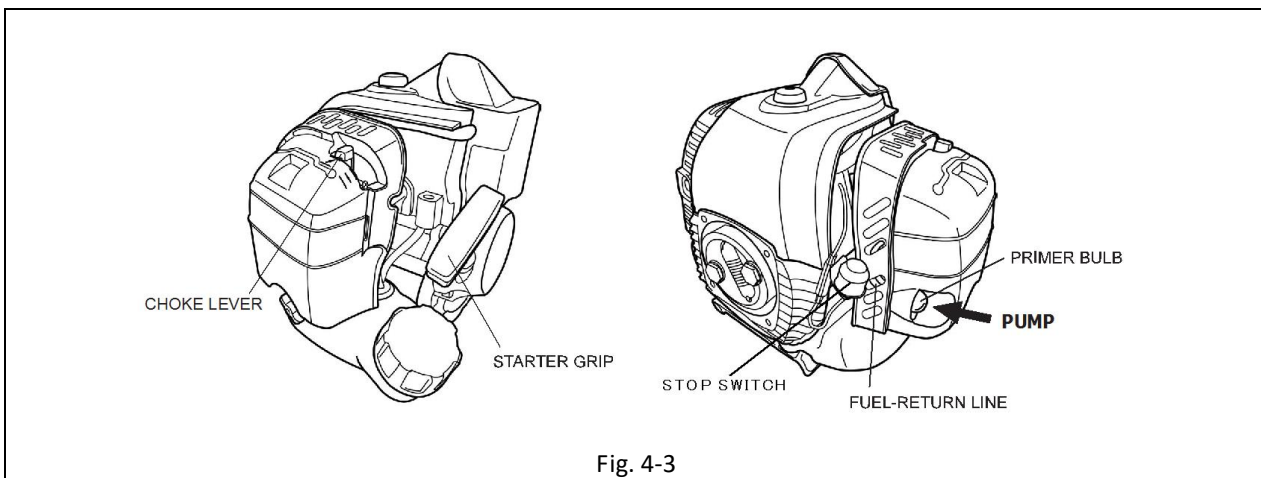

Fig. 4-3

**⚠ Caution**

**● Adjusting idling speed**

The carburetor of the engine of this product cannot be adjusted. Only idle speed can be adjusted.

The rotation speed is about 2500-3000rpm when idling  
To adjust the idling speed, slowly turn the adjusting screw while idling. (Fig. 4-4)

- To speed up idling, turn the adjustment screw clockwise.
- To speed down, turn the adjustment screw counterclockwise.
- Adjust should be made when the engine is running.
- Be careful not to touch the moving parts.
- Please remove the tip tool etc.
- Keep people away during the adjustment.

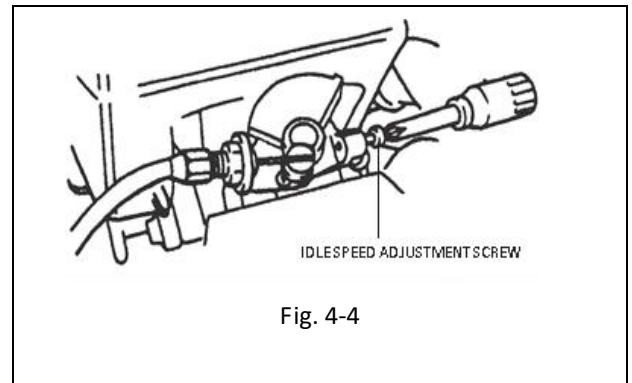

Fig. 4-4

**⚠ Caution**

**● Switching rotation direction**

When the gear change lever (Fig. 4-1) is set to "R", it rotates clockwise.

When set to "L", it will rotate counterclockwise.

When the gear change knob is hard to turn when the engine is working, pull the trigger a little to unlock.

When the gear change knob is hard to turn when the engine is not working, turn the anvil a little to unlock.

Do not turn gear change knob while pulling the throttle lever.

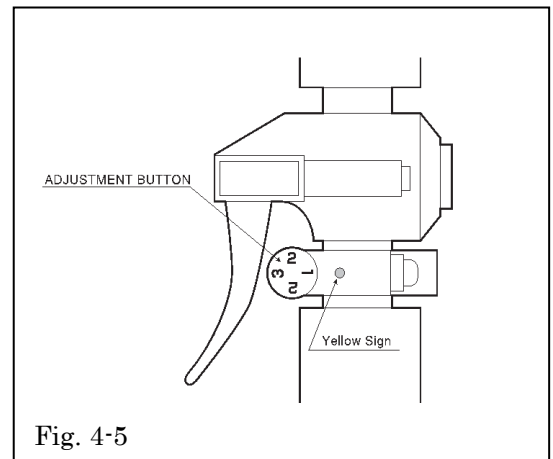

Fig. 4-5

**⚠ Caution**

**● Adjustment of torque**

This product has full throttle mode and half throttle mode by pushing adjustment button. You can make fine adjustments using the adjustment switch during half throttle.

"1 "is maximum, "3 " is minimum.

**⚠ Caution**

**● Installation of socket**

There is a pin hole at the end of the anvil (□ drive). This have to be aligned with the pin hole of the socket and secured with the pin and O-ring.

- \* If not securely fixed, the socket may come off and pop out, which could be harmful. In addition, never run idle with a socket

**⚠ Warning**

**About handling**

- \* Do not touch rotating parts. It is very dangerous and may cause injury.
- \* Do not run idle with the accessory tool attached.
- \* Check the direction of rotation before starting the product.
- \* Be sure to stop the engine when you stop or finish the work, or when you change the tools and parts.
- \* Do not touch the tools and screws during work because they are hot due to friction.
- \* Engine and other parts become hot. Do not touch anything other than the handle or the operation unit.
- \* If an abnormal occurs, stop the engine immediately and stop the work.

**⚠ Caution**

● **Air filter** (Fig. 5-1)

**Maintenance intervals**

• Clean every 100 hours and more often if used in a dusty working environment.

**How to clean the air filter**

1. Remove the filter cover and the foam element.
2. Rinse with warm soapy water. Dry the filter completely before use.
3. Apply a thin coat of SAE30 motor oil to the filter and remove any excess oil.
4. Reassemble the filter cover and the foam element.

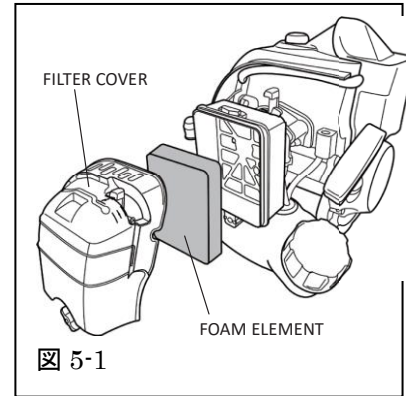

**⚠ Caution**

● **Fuel filter**

**Maintenance intervals**

The fuel filter must be replaced every 100 hours of operation

**How to replace the fuel filter** (Figure 5-2)

The fuel filter is attached to the end of the pickup hose in the fuel tank

Replacement procedure :

1. Ensure that the engine is not running.
2. Make sure the fuel tank is empty.
3. Loosen the fuel tank cap and remove it.
4. Using a wire hook, carefully pull out the fuel filter from the fuel tank.
5. Grab the fuel hose and remove the filter. Be careful not to disconnect the fuel hose at that time
6. Replace the fuel filter while holding the fuel hose
7. Carefully return the new fuel filter to the fuel tank
8. Before refueling, check that the fuel filter is not trapped in the corner of the fuel tank and that the hose is not twisted or broken.

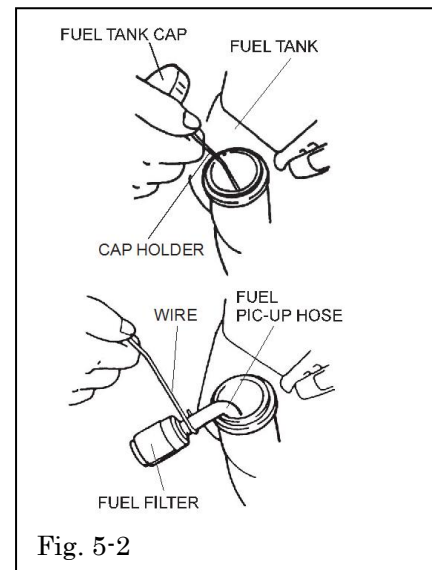

**⚠ Caution**

● **Spark plug**

• It is necessary to remove the spark plug from the engine and check it every 25 hours

• Replace the spark plug every 100 hours of operation

**Maintenance of spark plug (Fig. 5-3)**

1. Cool down the engine and remove the socket head screws and remove the Rear cover by lifting up rib as Figure 5-3.
2. Twist the connecting cord boot of the spark plug back and forth several times to loosen the boot, and pull it out from spark plug.
3. Remove the spark plug with the correct tool
4. Clean the electrodes with a brush
5. Adjust the electrode gap to 0.6mm-0.7mm
6. Replace Spark plug when it is dirty, damaged, or worn out.
7. Be careful not to overtighten the spark plug during installation. (Tightening torque is 10.7Nm-16.6Nm)
8. Reassemble the rear cover and tighten the screw.

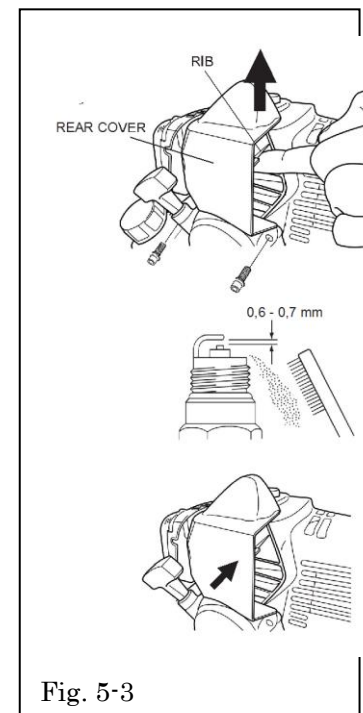

**⚠ Caution**

**● Long-term storage**

Transfer remaining fuel to a suitable fuel storage container

- 1 Run the engine to remove any remaining fuel in the carburetor
- 2 Perform necessary maintenance and repairs.
- 3 Remove the spark plug and put a little engine oil in the cylinder.
- 4 Slowly pull the starter to move the piston to the top of the cylinder.
- 5 Reinstall the spark plug
- 6 Store the machine in a dry place without excessive heat, sparks or fire.
  - When the starter is pulled without the spark plug, oil may blow out from the opening.
  - It is dangerous if oil gets into your eyes or gets on your skin.
  - Wear protective equipment such as eyeglasses and remove your face from the opening when you pull the starter.

We recommend periodic inspections otherwise it will affect the performance, lifetime and safety of the product.

- Inspection (maintenance) should be performed only by those who have read and understood the instruction manual for this product.
- For repairing, contact your dealer and don't do it yourself.

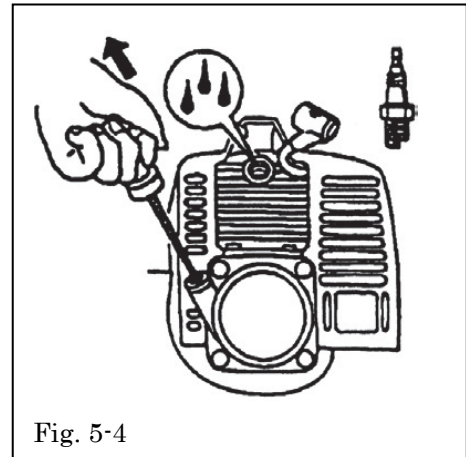

Fig. 5-4

**⚠ Warning**

**● Spark Arrester**

**POTENTIAL HAZARD**

▪ Muffler surface, Tail pipe and Adjustable tail pipe becomes hot when GT-3500GE-V is in operation and remains hot for some time after the engine is shut off.

**WHAT CAN HAPPEN**

▪ Contact with hot muffler surface, Tail pipe and Adjustable tail pipe could cause a burn.

**HOW TO AVOID THE HAZARD**

▪ Make sure the muffler, Tail pipe and Adjustable tail pipe is cool before inspecting and cleaning the spark arrester.

**Maintenance Interval**

·The spark arrester should be inspected and cleaned after every 25 hours of operation.

Replace the screen if it cannot be thoroughly cleaned or if it is damaged.

**● Spark Arrester Maintenance**

- 1 Tail pipes and adjustable tail pipes are very dangerous as they become hot after use. Wait for the temperature to decrease before servicing the spark arrester.
- 2 Loosen the Phillips screw (M4 x 8) (part number 395) and pull the adjustable tail pipe (part number 394) to remove it.
- 3 Pull out the spark arrester (part number 396) from the tail pipe bracket (part number 340).
- 4 Clean spark arrester with a non-flammable solvent and a hard brush.
- 5 Be careful not to deform the spark arrester when removing or cleaning.
- 6 Insert the cleaned and dry spark arrester into the tail pipe bracket.
- 7 Insert the adjustable tail pipe into the tail pipe bracket with the spark arrester inside.
- 8 Adjust the angle of the inserted adjustable tail pipe and tighten the Phillips screw (M4 x 8) with the U nut (part number 358) to secure it.

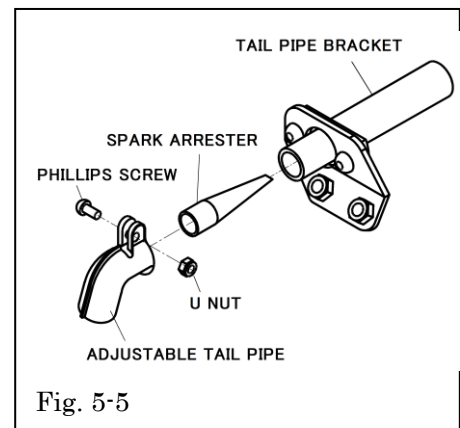

Fig. 5-5

**⚠ Caution**

**Product inspection range**

When performing the inspection, be sure the engine is stopped and empty. The durability of parts differs depending on the frequency of use.

## CHAPTER5 Maintenance and inspection

When the impact or rotation sound is abnormal (the impact rhythm is different, the work efficiency is reduced, the vibration is large, etc.) request inspection and repair.

### ● Anvil (□ drive at the tip)

Wear out : Reduce performance and efficiency. We recommend early replacement.

Cracks. There is a risk of breakage, so stop using and request a repair.

### ●Socket

Wear out of square part: It may cause performance degradation and fall off from the anvil.

Worn pinholes: Cannot be fixed and may fall of the anvil.

Cracks: There is a risk of breakage and scattering. Stop using and replace with a new one.

### ●Throttle lever

When pulling the throttle lever, take care that there is no abnormality in pulling or returning.

### ●Bolts

Make sure all the bolts are tightened.

### ● Leakage of fuel or oil

Engine: If fuel leakage is confirmed, it may cause an accident or malfunction. Stop using it immediately, check the engine, and request repair if necessary.

Main unit: If an oil leak is confirmed, it may cause an accident or breakdown. Stop using the unit immediately, check the unit, and request repair if necessary.

### ● Fuel pipe

Check that the fuel pipe is not twisted or broken. When it is broken, please replace it.

## CHAPTER6 Trouble shooting

### ⚠ Caution

#### Trouble shooting

Symptoms	Cause	treatment
Engine does not start	<Fuel system>	
	Fuel tank is empty	Refuel the mixed gasoline.
	Insufficient pressing of priming pump	Press Priming pump for several and send the fuel.
	Fuel pipe bent or damaged	Fix or replace of fuel pipe.
	Carburetor damage	Replace or repair
	Wet spark plug due to too much intake of fuel.	1 Remove the spark plug 2 Exhaust exceeded fuel by pulling the starter handle 5 or 6 times. 3 Install spark plug 4 Turn choke lever to opens and pull the starter handle.
	<Electrical system>	
	Dirt on spark plug	Clean up or replace
	No spark from spark plug	1 Ignition coil bad connection 2 Improper gaps between spark plug electrodes 3 Ignition coil failure
	Improper gap between spark plug electrodes	Adjust to 0.6-0.7mm.
Defective ignition coil	Replace	
Idling abnormality	Idling speed is not set correctly	Setting the idling speed
Lack of power	Air filter dirt	Cleaning or replacing the air filter
	Hammer wear	Replace
	Gear breakage	Replace
Engine stops	Fuel shortage	Refuel the mixed gasoline.
	Chalk position is closed	Open the chalk.
	Carburetor abnormalities	Replace or repair.
	Fuel pipe breakage	Replace or repair.
Poor rotation	Gear breakage	Replace or repair.
	Damage to gear change lever	Replace or repair.

If the product is used with a defect or abnormal condition, it may lead to a failure or accident.

Request repair immediately to your dealer

● Engine exploded view 1

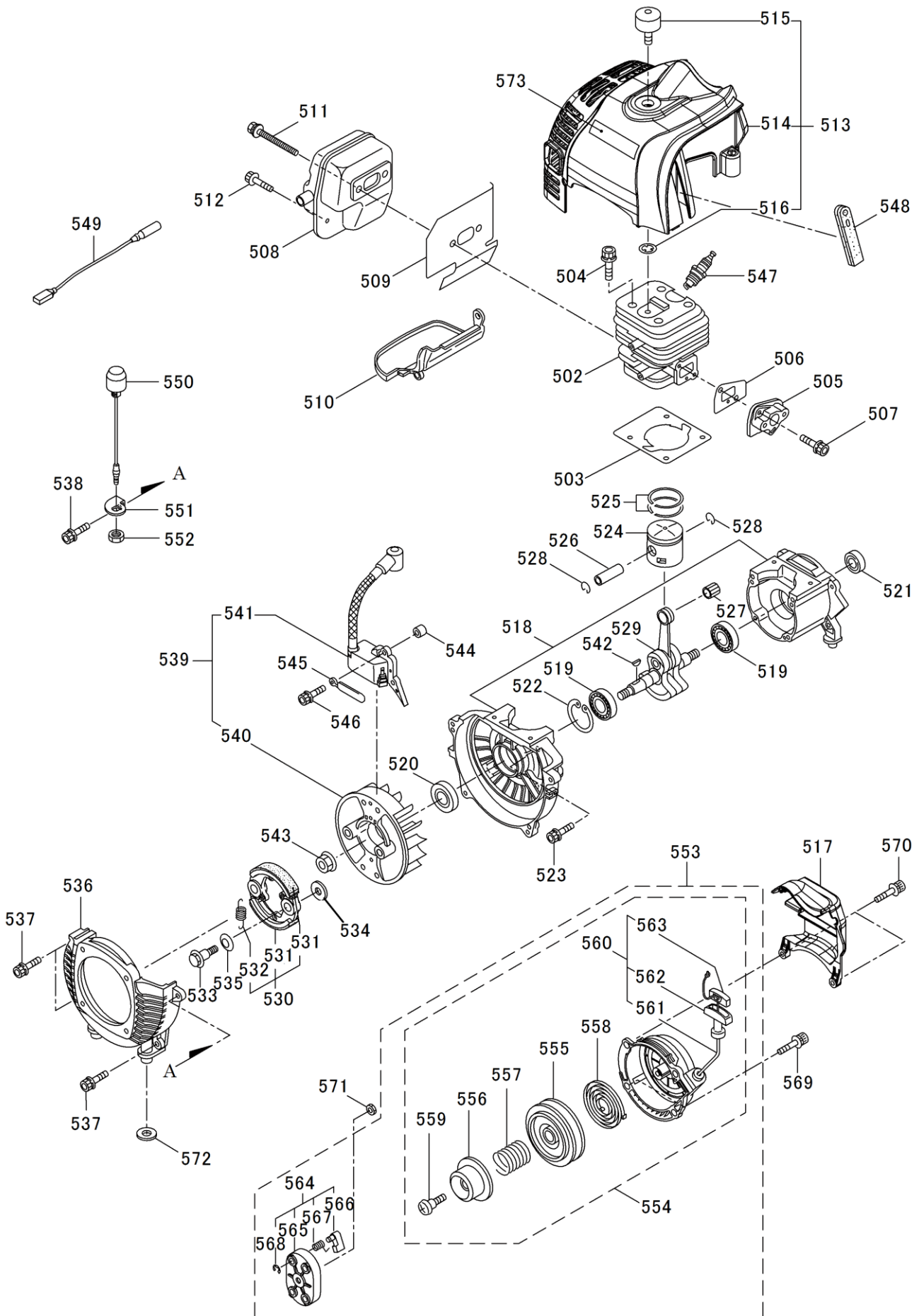

**CHAPTER7** Exploded view / parts list

Part No.	EDP No.	Parts name	Size	One-unit quantity
502	848502	Cylinder		1
503	848503	Gasket		1
504	848504	Hexagon socket head bolt	M5 × 25	4
505	848505	Insulator		1
506	848506	Gasket		1
507	848507	Hexagon socket head bolt	M5 × 25WSW	2
508	848508	Muffler		1
509	848509	Gasket		1
510	848510	undercover		1
511	848511	Hexagon socket head bolt	M5 × 60	2
512	848512	Hexagon socket head bolt	M5 × 12W-12	1
513	848513	Top cover assembly	(Built -in parts No.514- No.516)	1
< 514 >	848514	Top cover	(Parts Nanba1 3 built-in parts)	1
< 515 >	848515	Knob bolt	(Parts Nanba1 3 built-in parts)	1
< 516 >	848516	Cap bottom washer	(Part No.1 3 Built-in parts) M6	1
517	848517	Rear cover		1
518	848518	Crankcase		1
519	848519	Bearing	6202 C3	2
520	848520	Oil seal		1
521	848521	Oil seal		1
522	848522	C-type retaining ring	35 for holes	1
523	848523	Hexagon socket head bolt	M5 × 30	4
524	848524	Piston		1
525	848525	Piston ring		2
526	848526	Piston pin	7.5 × 11 × 33.5	1
527	848527	Needle Bearing	KTV111414EG01B2	1
528	848528	Circlip		2
529	848529	Shaft complete (crankshaft)		1
530	848530	Clutch assembly	(Built -in parts No.531- No.532)	1
< 531 >	848531	Clutch show (clutch arm)	(Part No. 530 Built-in part)	2
< 532 >	848532	Clutch spring	(Part No.530 built-in part) 2.3-44.8L	1
533	848533	Clutch bolt	M8 × 1.25	2
534	848534	Plain washer	8 × 22 × T1.2	2
535	848535	Wave washer		2
536	848536	Fan cover		1
537	848537	Hexagon socket head bolt	M5 × 20WSW	3
538	848538	Hexagon socket head bolt	M5 × 25WSW	1
539	848539	Magnet assembly	(Part No.540- No.541 built-in)	1
< 540 >	848540	Rotor	(Part No.539 built-in part)	1
< 541 >	848541	Ignition coil assembly	(Part No.539 built-in part)	1
542	848542	Woodruff key	3 × 10	1
543	848543	Nuts with countersunk washers	M10 × 17 × t8	1

## CHAPTER7 Exploded view / parts list

544	848544	Spacer		2
545	848545	Clamp	M4	1
546	848546	Hexagon socket head bolt	M4 × 25WSW	2
547	848547	Spark plug	BPMR8Y	1
548	848548	Grommet		1
549	848549	Lead		1
550	848550	Stop switch assembly		1
551	848551	Stay		1
552	848552	Small hexagon nut	M8 × 1	1
553	848553	Recoil starter assembly	(Part No. 554-No. 568 built-in)	1
< 554 >	848554	Starter assembly	(Part No. 553 built-in part) (Part No. 555-No. 563 built-in)	1
< 555 >	848555	Reel	(Part No. 554 Built-in part)	1
< 556 >	848556	Cam plate	(Part No.554 Built-in part)	1
< 557 >	848557	Damper spring	(Part No. 554 Built-in part)	1
< 558 >	848558	Spiral spring	(Part No. 554 Built-in part)	1
< 559 >	848559	Set screw	(Part No. 554 Built-in part)	1
< 560 >	848560	Rope assembly	(Part No. 554 built-in part) (Part No. 561-No. 563 built-in)	1
< 561 >	848561	Starter rope	(Part No.561-No.563 built-in)	1
< 562 >	848562	Starter knob	(Part No.561-No.563 built-in)	1
< 563 >	848563	Knob cap	(Part No.561-No.563 built-in)	1
< 564 >	848564	Starter pulley assembly	(Part No. 553 built-in part) (Part No. 565-No. 568 built-in)	1
< 565 >	848565	Starter pulley	(Part No. 565 built-in part)	1
< 566 >	848566	Ratchet	(Part No. 565 built-in part)	2
< 567 >	848567	Return spring	(Part No. 565 built-in part)	2
< 568 >	848568	E-type retaining ring	(Part No. 565 built-in part)	2
569	848569	Hexagon socket head bolt	M5 × 18WSW	2
570	848570	Hexagon socket head bolt	M5 × 25L	2
571	848571	Nut (Hex low nut)	M8	1
572	848572	Packing	17 × 8 × 2	4
573	848573	Label		1

The <> mark is a built-in part, so be careful when ordering.



● Engine exploded view2

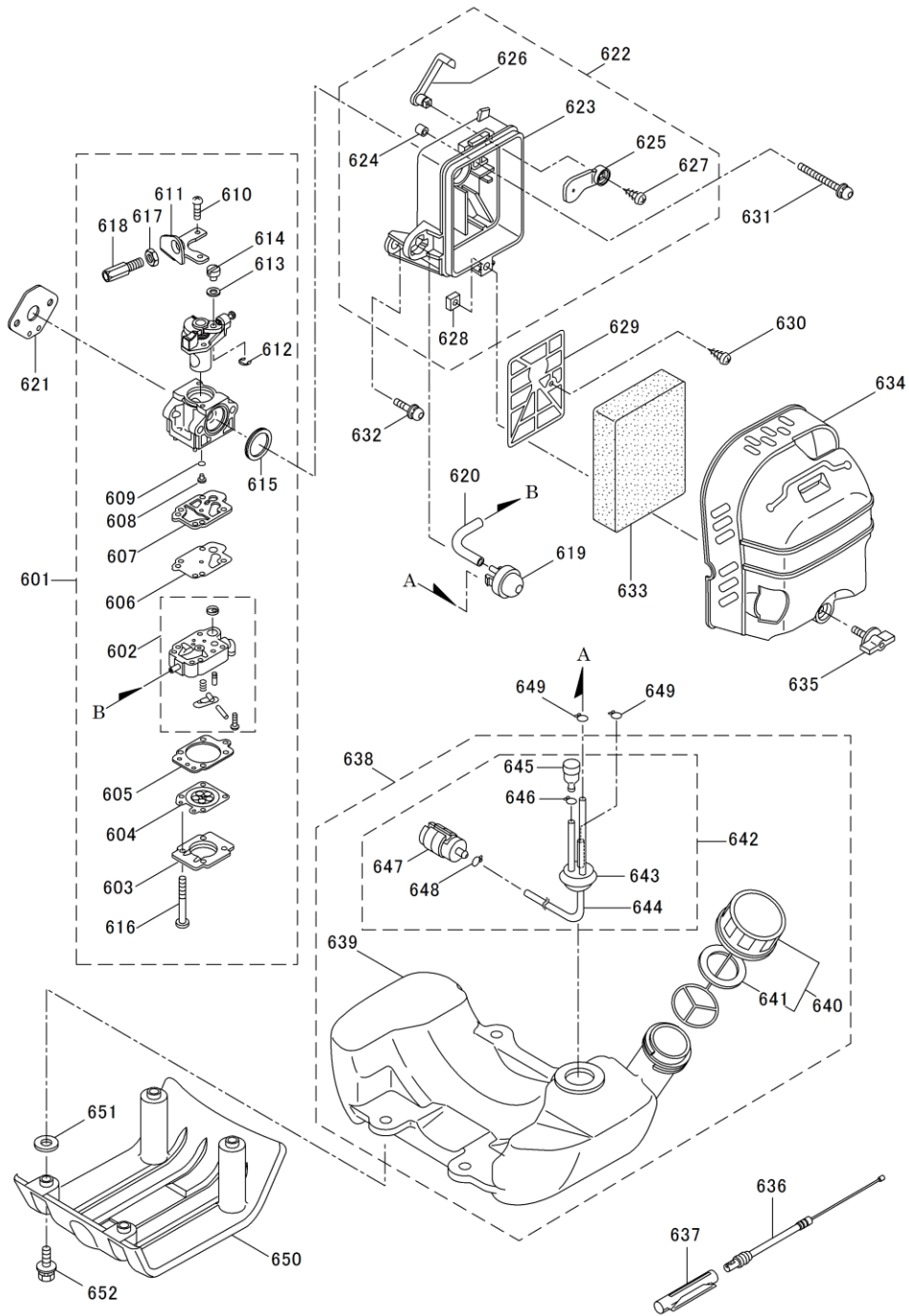

Part No.	EDP No.	Parts name	Size	One unit quantity
601	848601	Carburetor assembly	(Built-in parts No.102-No.118)	1
< 602 >	848602	Pump body	(Part No. 101 built-in part)	1
< 603 >	848603	Cover Plate	(Part No. 101 built-in part)	1
< 604 >	848604	Metering diaphragm (diaphragm)	(Part No. 101 built-in part)	1
< 605 >	848605	Gasket	(Part No. 101 built-in part)	1
< 606 >	848606	Fuel pump diaphragm (diaphragm)	(Part No. 101 built-in part)	1
< 607 >	848607	Gasket	(Part No. 101 built-in part)	1
< 608 >	848608	Jet	(Part No. 101 built-in part)	1
< 609 >	848609	O-ring	(Part No. 101 built-in part)	1

## CHAPTER7 Exploded view / parts list

< 610 >	848610	Screw	(Part No. 601 built-in part)	2
< 611 >	848611	Bracket	(Part No. 601 built-in part)	1
< 612 >	848612	E-ring	(Part No. 601 built-in part)	1
< 613 >	848613	Washer	(Part No. 601 built-in part)	1
< 614 >	848614	Swivel	(Part No. 601 built-in part)	1
< 615 >	848615	Packing	(Part No. 601 built-in part)	1
< 616 >	848616	Screw	(Part No. 601 built-in part)	4
< 617 >	848617	Hexagon nut	(Part No. 601 built-in part) M6	1
< 618 >	848618	Adapter	(Part No. 601 built-in part)	1
619	848619	Pump		1
620	848620	Pipe		1
621	848621	Gasket		1
622	848622	Case assembly	(Built-in parts No.623-No.628)	1
< 623 >	848623	Case body	(Part No. 622 Built-in part)	1
< 624 >	848624	Sleeve	(Part No. 622 Built-in part)	3
< 625 >	848625	Valve	(Part No. 622 Built-in part)	1
< 626 >	848626	Lever	(Part No. 622 Built-in part)	1
< 627 >	848627	Screw	(Part No. 622 Built-in part) M3.5 × 8	1
< 628 >	848628	Square nut	(Part No. 622 Built-in part) M5	1
629	848629	Screen		1
630	848630	Screw	M3.5 × 8	1
631	848631	Hex Socket Button Bolt	M5 × 50WSW	2
632	848632	Hex Socket Button Bolt	M5 × 16WSW	1
633	848633	Element		1
634	848634	Cleaner cover		1
635	848635	Knob		1
636	848636	Wire complete		1
637	848637	Connector case		1
638	848638	Fuel tank assembly	(Built-in parts No.639-No.648)	1
< 639 >	848639	Fuel tank	(Part No. 638 built-in part)	1
< 640 >	848640	Fuel tank cap assembly	(Part No. 638 built-in parts) (parts No.641 built-in)	1
< 641 >	848641	Packing	(Part No. 641 built-in part)	1
< 642 >	848642	Fuel pipe assembly	(Part No. 638 built parts) (internal components No.643-No.648)	1
< 643 >	848643	Grommet	(Part No. 642 Built-in part)	1
< 644 >	848644	Fuel pipe	(Part No. 642 Built-in part) 180L	1
< 645 >	848645	Breather subassembly	(Part No. 642 Built-in part)	1
< 646 >	848646	Clip	(Part No. 642 Built-in part)	1
< 647 >	848647	Filter assembly	(Part No. 642 Built-in part)	1
< 648 >	848648	Clip	(Part No. 642 Built-in part)	1
649	848649	Clip		2
650	848650	Stand		1
651	848651	Packing	17 × 8 × 2	4
652	848652	Hex Socket Button Bolt	M5 × 20WSW	4

The <> mark is a built-in part, so be careful when ordering.

●Exploded view of 3500GE-V Impact part

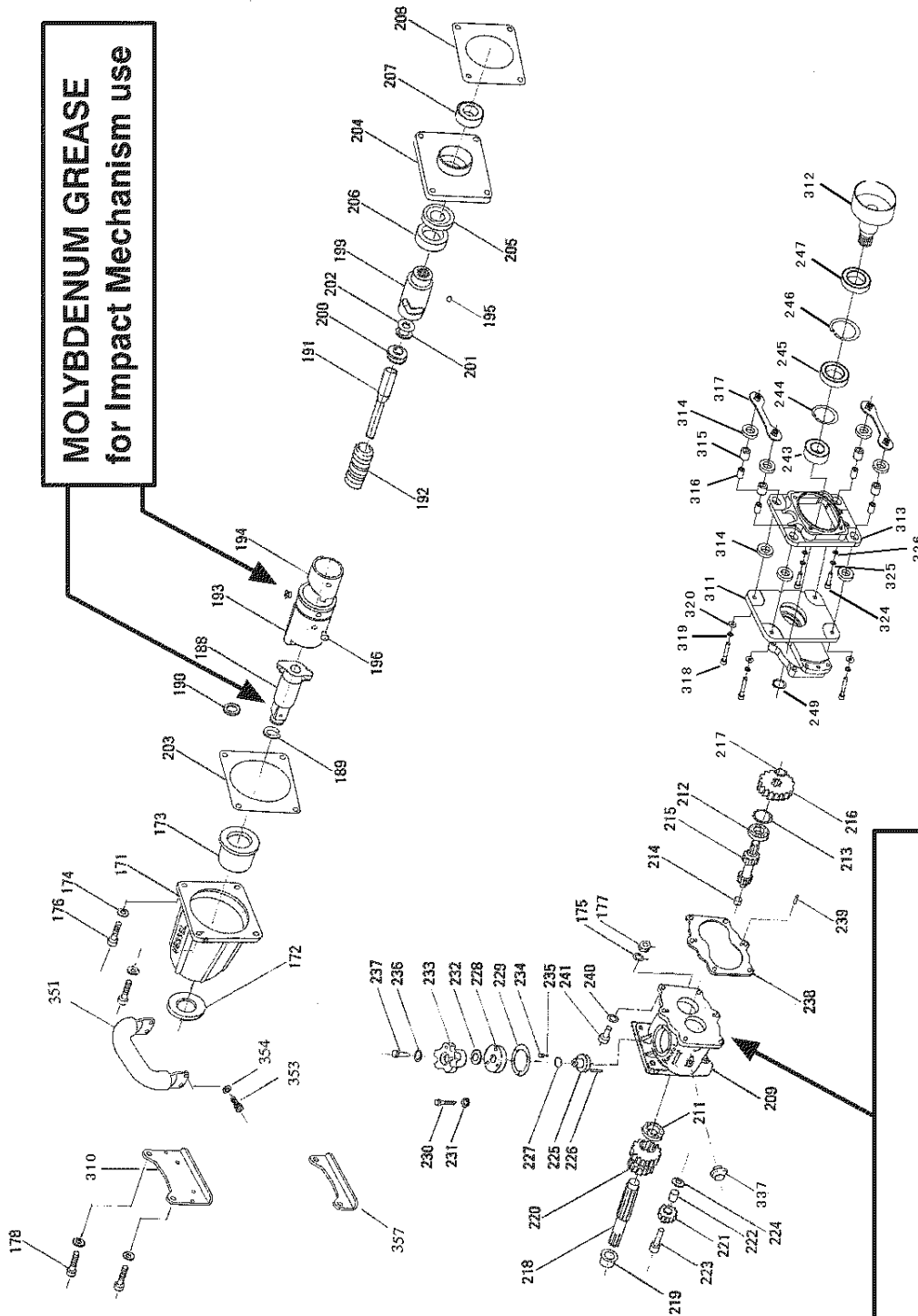

**CHAPTER7** Exploded view / parts list

Part No.	EDP No.	Parts name	Size	One-unit quantity
171	845171	Hammer case	(Built-in parts No.172-No.173)	1
< 172 >	845172	Oil seal	(Part No. 171 built-in part) VB type 35 × 50 × 5	1
< 173 >	845173	Hammer case press-fit bush	(Part No. 171 built-in part)	1
174	845174	Serrated spring washers with knurls	2H-M8	4
175	845175	Spring washer	M8	3
176	845176	Hexagon socket head bolt	M8 × 45	3
177	845177	U-nut	M8 U-nut	3
178	845178	Hexagon socket head bolt	M8 × 50	1
188	845188	Retainer ring anvil complete	(Built-in parts No.189-No.190)	1
< 189 >	845189	Retainer Ring	(Part No. 188 built-in part)	1
< 190 >	845190	Retainer ring O-ring	(Part No. 188 built-in part) P18	1
191	845191	Central shaft		1
192	845192	Return spring		1
193	845193	Hammer complete	(Parts Nanba194, Nanba19 6 built-in)	1
< 194 >	845194	Cam plate	(Part No. 193 built-in part)	1
195	845195	Wrecking ball	φ 13/32	2
< 196 >	845196	Steel plug	(Part No. 193 built-in part)	4
199	845199	Clutch		1
200	845200	Thrust bearing	NSK 51104 (steel cage)	1
201	845201	Spacer		1
202	845202	Thrust		1
203	845203	Hammer case packing		1
204	845204	Ring flange complete	(Built-in parts No.205-No.207)	1
< 205 >	845205	Oil seal	(Part No.204 built-in part) SC type 30 × 52 × 7	1
< 206 >	845206	Bearing	(Part No.204 internal parts) 6007VV	1
< 207 >	845207	Bearing	(Part No.204 Built-in part) 6006	1
208	845208	Ring flange packing		1
209	845209	Gear case complete	(Part No.211, No.214, No.337 built-in)	1
< 211 >	845211	Bearing	(Part No. 209 built-in part) 16004 (NSK)	1
212	845212	Bearing	16003 (NSK)	1
213	845213	Round R type retaining ring	IRTW-35	1
< 214 >	845214	Selector shaft bush	(Part No. 209 built-in part)	1
215	845215	Selector shaft		1
216	845216	Gear		1
217	845217	C type snap ring for shaft	STW-16	1
218	845218	Bearing shaft complete	(Part No.219 built-in)	1
< 219 >	845219	Bearing shaft bush	(Part No.218 built-in part)	1
220	845220	Gear cluster		1
221	845221	Planet Gear Complete	(Built-in part No.222)	1
< 222 >	845222	Planet gear bush	(Part No.221 built-in part)	1
223	845223	Planet pivot		1
224	845224	Planet spacer		1
225	845225	Gear selector complete	(Part No.226 built-in)	1

**CHAPTER7** Exploded view / parts list

< 226 >	845226	Spiral pin	(Part No.225 internal parts) Fai 5 × 26 (Orbis powerful type)	1
227	845227	O-ring	N14	1
228	845228	Gear flange		1
229	845229	Gear flange packing		1
230	845230	Hexagon socket head bolt	M5 × 10	3
231	845231	Serrated spring washers with knurls	2L-M5	3
232	845232	Wave washer	WW-16	1
233	845233	Gear change knob		1
234	845234	Gear selector stop spring	S3.8 × 7 × 0.6 × 6	1
235	845235	Gear selector stop ball	φ4 steel ball	1
236	845236	Spring washer	M6	1
237	845237	Hexagon socket head bolt	M6 × 20	1
238	845238	Gear case packing		1
239	845239	Positioning pin	Needle roller φ4 × 13.8	2
240	845240	Serrated spring washers with knurls	2H-M6	6
241	845241	Hexagon socket head bolt	M6 × 25	6
< 243 >	845243	Bearing	(Part No.311 built-in part) 16005	1
< 244 >	845244	Round R type retaining ring	(Part No.311 built-in part) IRTW-47	1
< 245 >	845245	Bearing	(Part No.311 built-in part) 6907	1
< 246 >	845246	Round R type retaining ring	(Part No.311 built-in part) IRTW-55	1
< 247 >	845247	Oil seal	(Part No.311 built-in part) SC type 35 × 55 × 8	1
249	845249	C type snap ring for shaft	STW-25	1
310	848310	Footrest		1
311	848311	Clutch support flange complete	(Part-Nanba247 Nanba243, 337 built-in)	1
312	848312	Clutch ring		1
313	848313	Engine support flange		1
314	848314	Damper rubber		8
315	848315	Urethane color		4
316	848316	Color		4
317	848317	Damper rubber receiver		2
318	848318	Hexagon socket head cap screw (half screw)	M6 × 35	4
319	848319	Spring washer	M6	4
320	848320	Flat washer	M6	4
324	848324	Hexagon socket head bolt	M6 × 22	4
325	848325	Spring washer	M6	4
326	848326	Serrated spring washers with knurls	M6	4
< 337 >	848337	Oil pot port	(Part No.311 built-in part ) PF3 / 8 -19(steel)	1
351	845351	Anti-vibration D handle	(With rubber)	1
353	845353	Hex Socket Button Bolt	M6 × 16	4
354	845354	Serrated spring washers with knurls	2H-M6	4
357	845357	Footrest (short)	15mm	1

The <> mark is a built-in part, so be careful when ordering.

●3500GE-V handle section exploded view

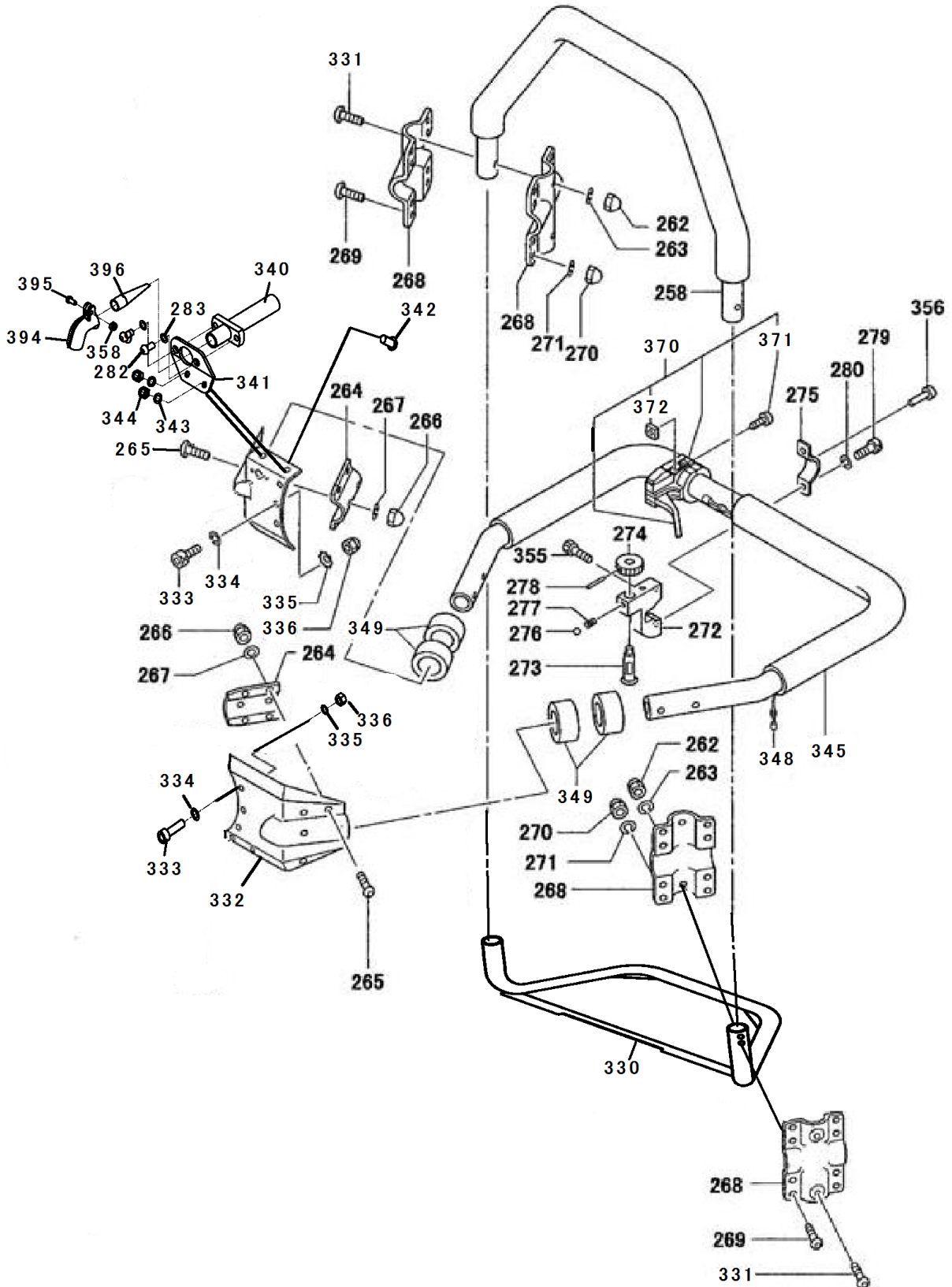

Part No.	EDP No.	Parts name	Size	One unit quantity
258	845258	Vibration-proof auxiliary handle	(With rubber)	1
262	845262	Hex U nut	M5 U-nut	4
263	845263	Spring washer	M5	4

**CHAPTER7** Exploded view / parts list

264	845264	Plate for Handle		2
265	845265	Hex Socket Button Bolt	M5 × 16	8
266	845266	Hex U nut	M5 U-unit	8
267	845267	Spring washer	M5	8
268	845268	Auxiliary handle bracket		4
269	845269	Hex Socket Button Bolt	M5 × 14	16
270	845270	Hex U nut	M5 U-unit	16
271	845271	Spring washer	M5	16
272	845272	Adjust base complete	(Part No. 273,247,276,277,278 AND 355 built-in)	1
< 273 >	845273	Adjust valve	(Part No.272 built-in part)	1
< 274 >	845274	Adjust button	(Part No.272 built-in part)	1
275	845275	Adjust bracket		1
< 276 >	845276	Adjusting stop ball	(Part No.272 internal parts) Fai 4 steel balls	1
< 277 >	845277	Adjusting stop spring	(Part No.272 built-in part) S3.8 × 0.6	1
< 278 >	845278	Adjustment button fixing pin	(Part No.272 built-in part) SP2.5 × 16	1
279	845279	Hex Socket Button Bolt	M5 × 12	2
280	845280	Spring washer	M5	2
282	845282	Hex Socket Button Bolt	M6 × 12	2
283	845283	Serrated spring washers with knurls	2H-M6	2
330	848330	Protection pipe complete	(Weld protective cover)	1
331	848331	Hex Socket Button Bolt	M5 × 30	4
332	848332	Handle bracket		2
333	848333	Hexagon socket head bolt	M6 × 22	6
334	848334	Spring washer	M6	6
335	848335	Serrated spring washers with knurls	2H-M6	6
336	848336	Hex U nut	M6 U-unit	6
340	848340	Tail pipe bracket		1
341	848341	Tail pipe base		1
342	848342	Hex Socket Button Bolt	M6 × 12	2
343	848343	Spring washer	M6	2
344	848344	Hexagon nut	M6 U set	2
345	848345	Main handle		1
348	848348	Throttle wire HD		1
349	848349	Handle damper rubber		4
< 355 >	845355	Hexagon socket head bolt	(Part No.272 built-in part) M5 × 14	2
356	845356	Rivet		1
358	848358	U nut	M4	1
370	848370	Throttle lever assembly		1
371	848371	Phillips bolt	M5 × 20	2
372	848372	Nut	M5	2
394	848394	Adjustable tail pipe		1
395	848395	Phillips screw	M4 × 8	1
396	848396	Spark Arrester		1

●3500GE-V damper unit exploded view

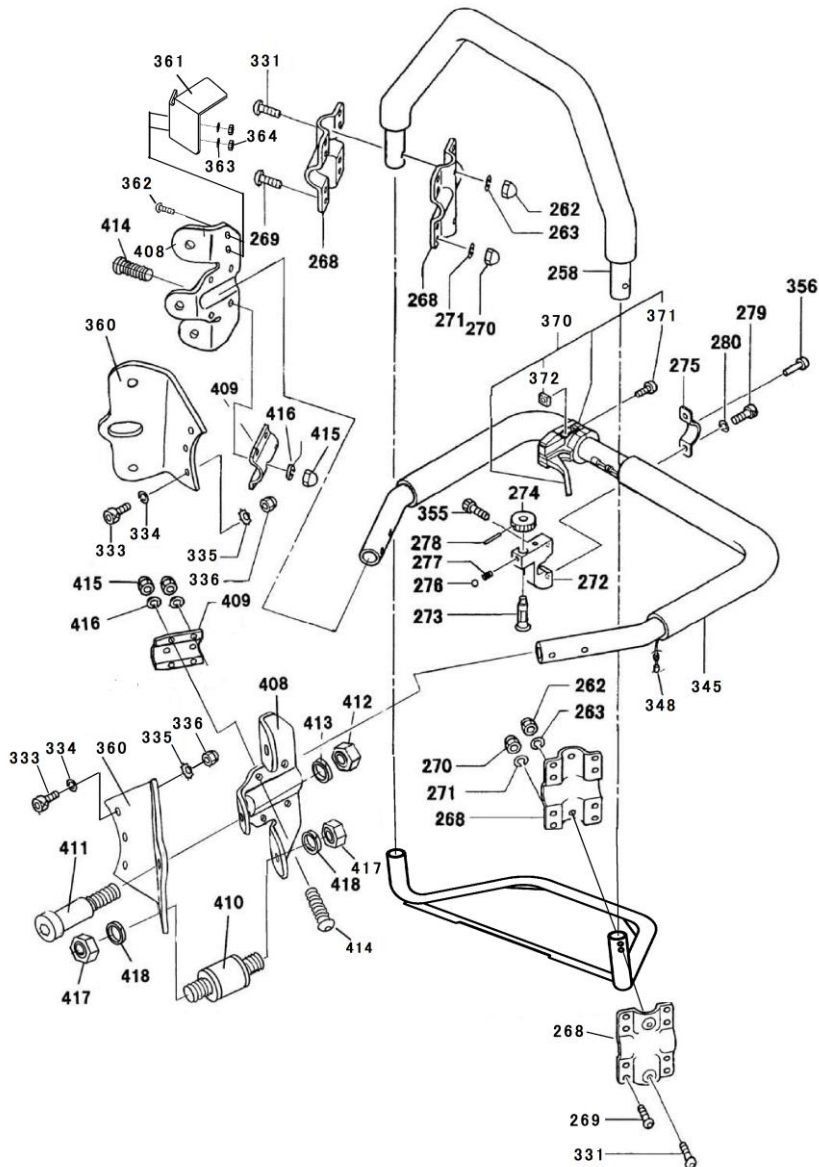
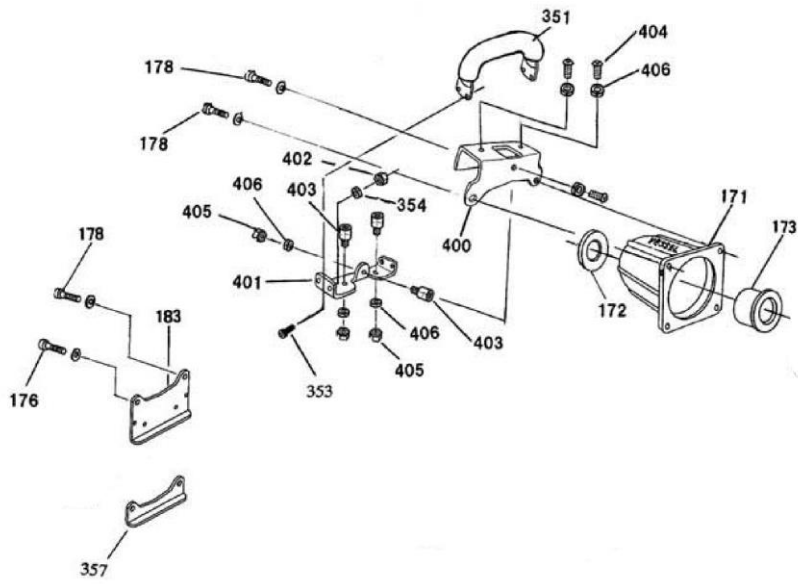



**CHAPTER7** Exploded view / parts list

Part No.	EDP No.	Parts name	Size	One-unit quantity
360	848360	Anti-vibration handle base		2
361	848361	Exhaust cover		1
362	848362	Hex Socket Button Bolt	M5 × 14	2
363	848363	Serrated spring washers with knurls	M5	2
364	848364	Hex U nut	M5	2
400	845400	Anti-vibration D handle receiver		1
401	845401	Anti-vibration D handle base		1
402	845402	Hex U nut	M6	4
403	845403	Anti-vibration rubber	VK25CR (Bolts 12)	3
404	845404	Hex socket button bolt	M6 × 12	3
405	845405	Hex U nut	M6	3
406	845406	Spring washer	M6	6
408	845408	Anti-vibration handle bracket		2
409	845409	Anti-vibration handle receiver		2
410	845410	Anti-vibration rubber	VK35CR (35H hardness 45 bolt length 15)	4
411	845411	Hex socket shoulder bolt	φ12 × 16 M10	2
412	845412	Hex U nut	M10	2
413	845413	Spring washer	M10	2
414	845414	Hex socket button bolt	M6 × 16	8
415	845415	Hex U nut	M6	8
416	845416	Spring washer	M6	8
417	845417	Hex U nut	M8	8
418	845418	Spring washer	M8	8

# VESSEL

EC DECLARATION OF CONFORMITY

## EC適合宣言書

Name of company VESSEL FUKUCHIYAMA CO., LTD.  
社名 株式会社 ベツセル福知山  
Address 20-1, OSADANO-CHO 1-CHOME  
住所 FUKUCHIYAMA-SHI KYOTO 620-0853 JAPAN  
京都府福知山市長田野町1丁目20番地1

Declares, in sole responsibility, that the product  
独自の責任において、次の製品が

Model : GT-3500GE-V-AU

Referred to this declaration conforms with the standard(s) or directive(s)  
as far as applicable:

適用可能な範囲において次の指令または規格に適合していることを宣言する。

Standard : EN-792-6 : 2000  
EN-12096  
ISO 20643 (ISO 8662-1)  
ISO 28927-2 (ISO 8662-7)  
2016/1628  
Machinery Directive 2006/42/EC(98/37/EC)  
EMC Directive 2014/30/EU  
RoHS Directive 2011/65/EU  
Outdoor Noise Directive 2000/14/EC

The company named above will keep on file for review the following technical  
Documentation:

上記の者は、以下の技術資料を査察に備え保持する。

- Technical drawings 図面
- Other technical documentation その他技術資料

Importer/Distributor

Kyoto Japan February 1th, 2020

(自筆サイン) *Yasushi Shiomi*

Yasushi shiomi  
Engineering Dept.  
VESSEL FUKUCHIYAMA CO., LTD.



# VESSEL

76, HAZEMIYA-MACHI 1-CHOME,  
FUKUCHIYAMA-SHI, KYOTO, JAPAN  
Tel: 0773-27-1310  
Fax: 0773-27-1340

GB: EC DECLARATION OF CONFORMITY	— Individual machinery and safety components
F : DECLARATION DE CONFORMITE NORME CE	— Machine seule et composants de sécurité
D : CE KONFORMITÄTSERKLÄRUNG	— Gesamtmaschine und Sicherheitseinrichtungen
SP : DECLARACION DE CONFORMIDAD CE	— Maquinaria individual y componentes de seguridad
I : DICHIARAZIONE DI CONFORMITA CE	— Macchina singola e componenti di sicurezza
P : CE DECLARACAO DE CONFORMIDADE	— Maquinaria individual e dispositivos de segurança
NL : EG KONFORMITEITSVERKLARING	— Individuele machine en veiligheidscomponenten
DK : CE OVERENSSTEMMELSE DEKLARATION	— Enkle maskin og sikkerhedskomponenter
S : EG-DEKLARATION OM OVERENSSTÄMMELSE	— Individuella maskiner och säkerhetskomponenter
N : EF OVERENSSTEMMELSESERKLÆRING	— Individuel maskine og sikkerhedsudstyr
FIN : VAATIMUSTENMUKAISUUSVAKUUTUS	— Erilliset koneistot ja turvalaitteet
G : EC ΔΗΛΩΣΗ ΣΥΜΜΟΡΦΩΣΗΣ	— Ατομικά μηχανήματα και εξαρτήματα ασφαλείας

We, **VESSEL CO., INC.** OSAKA JAPAN, declare under our sole responsibility that the products: to which this declaration relates is in conformity with the following Machinery Directive and Standard: Machinery Directive 89/392/EEC, 91/368/EEC, 93/44/EEC, 93/68/EEC, 2006/42/EC (98/37/EC).

Model / Modele / Modell / Modelo /  
Modello / Modelo / Model / Model /  
Typ / Model / Malli / Μοντέλο

**GT-3500GE-AU**

Nous, **VESSEL CO., INC.** OSAKA JAPAN, déclarons sous notre responsabilité exclusive que le produit ci-dessous: est en conformité avec les exigences des déclarations communautaires concernant le rapprochement des législations des états membres relatives aux: Directives Machines 89/392/EEC, 91/368/EEC, 93/44/EEC, 93/68/EEC, 2006/42/EC (98/37/EC).

Wir, **VESSEL CO., INC.** OSAKA JAPAN, erklären hiermit unter alleiniger Verantwortung, daß das Produkt, auf das sich diese Erklärung bezieht, den Anforderungen der folgenden Maschinenrichtlinien und Standards entspricht: Maschinenrichtlinie 89/392/EEC, 91/368/EEC, 93/44/EEC, 93/68/EEC, 2006/42/EC (98/37/EC).

Nosotros, **VESSEL CO., INC.** OSAKA JAPAN, declaramos bajo nuestra sola responsabilidad, que el producto: al que se refiere esta declaración, está en conformidad con las siguientes Directivas y Standard de Maquinaria: Directiva Maquinaria 89/392/EEC, 91/368/EEC, 93/44/EEC, 93/68/EEC, 2006/42/EC (98/37/EC).

Noi, **VESSEL CO., INC.** OSAKA JAPAN, dichiariamo sotto la nostra unica responsabilità che il prodotto: cui questa dichiarazione si riferisce, è conforme alle seguenti Direttive: Direttiva Macchine 89/392/EEC, 91/368/EEC, 93/44/EEC, 93/68/EEC, 2006/42/EC (98/37/EC).

Nós, **VESSEL CO., INC.** OSAKA JAPAN, declaramos sob nossa exclusiva responsabilidade que os produtos: a que se refere esta declaração está em conformidade com os requisitos e padrões da Directiva de Maquinaria: Directiva de Maquinaria 89/392/EEC, 91/368/EEC, 93/44/EEC, 93/68/EEC, 2006/42/EC (98/37/EC).

Wij, **VESSEL CO., INC.** OSAKA JAPAN, verklaren onder onze exclusieve verantwoordelijkheid dat de artikelen op dewelke deze verklaring betrekking heeft, in overeenstemming zijn met volgende Machine Directieven en Standaarden: Machinery Directive 89/392/EEC, 91/368/EEC, 93/44/EEC, 93/68/EEC, 2006/42/EC (98/37/EC).

Vi, **VESSEL CO., INC.** OSAKA JAPAN, deklarerer under eneansvar at følgende produkter: som denne erklæring omhandler, er i overensstemmelse med følgende Maskin direktiv og standard: Machinery Directive 89/392/EEC, 91/368/EEC, 93/44/EEC, 93/68/EEC, 2006/42/EC (98/37/EC).

Name of and position of issuer / Nom et fonction de l'émetteur / Name and Position des Erstellers / Nombre y cargo del expedidor / Nome e posizione del dichiarante / Nome e cargo do emissor / Naam en functie van de uitgever / Udsteder, navn og stilling / Utsteders navn og stilling / Utfårdarens namn och befattning / Ilmoituksen antajan nimi ja asema / Ονομα και θέση εκδότη

Yasushi Shiomi, Plant Manager

Vi, **VESSEL CO., INC.** OSAKA JAPAN, deklarerar under eget ansvar att produkten till vilken denna deklaration relaterar sig är i överensstämmelse med de krav som finns i Rådets direktiv 89/392/EEC, 91/368/EEC, 93/44/EEC, 93/68/EEC, 2006/42/EC (98/37/EC).

Vi, **VESSEL CO., INC.** OSAKA JAPAN, deklarerer under eget ansvar at følgende produkter som denne erklæring omhandler, er i overensstemmelse med følgende Maskindirektiv og standard: Machinery Directive 89/392/EEC, 91/368/EEC, 93/44/EEC, 93/68/EEC, 2006/42/EC (98/37/EC).

Signature of issuer / Signature de l'émetteur / Unterschrift des Erstellers / Firma del expedidor / Firma del dichiarante / Assinatura do emissor / Handtekening van de uitgever / Udsteder, underskrift / Utsteders signatur / Utfårdarens namnteckning / Ilmoituksen antajan allekirjoitus / Υπογραφή εκδότη

Me, **VESSEL CO., INC.** OSAKA JAPAN, vakuutamme olevamme yksinomaisessa vastuussa siitä, että tämä tuote: johon tämä ilmoitus viittaa, on yhdenmukainen seuraavien konedirektiivien ja standardien kanssa: Konedirektiivi 89/392/EEC, 91/368/EEC, 93/44/EEC, 93/68/EEC, 2006/42/EC (98/37/EC).

**VESSEL Co., Inc.**

Εμείς, η **VESSEL CO., INC.** OSAKA JAPAN, δηλώνουμε υπ' ευθύνη μας ότι τα προϊόντα στα οποία η δήλωση αυτή αναφέρεται, συμμορφώνονται με τις παρακάτω Κοινοτικές Μηχανολογικές Οδηγίες και Πρότυπα. Μηχανολογική Οδηγία 89/392/EEC, 91/368/EEC, 93/68/EEC, 2006/42/EC (98/37/EC).

*Yasushi Shiomi*

# VESSEL

## CERTIFICATE OF INSPECTION

<b>MODEL</b>	GT-3500GE-V-AU	<b>SERIAL NO.</b>	
--------------	----------------	-------------------	--

We hereby certify that before shipment, above tool has been carefully inspected according to our factory engineering standard and the result has come out in satisfactory data. In order to maintain the best conditions of this tool, please be sure to take a few minutes to read through the enclosed instruction manuals and operate as recommended.

**DATE:** \_\_\_\_\_

**CHIEF INSPECTOR:** Akira Kuse

**Manufactured by :**

**VESSEL Co., Inc.**

17-25, Fukae-Kita 2-chome, Higashinari-ku,  
Osaka 537-0001 JAPAN

Tel : +81(0)6 6976 7778 Fax : +81(0)6 6972 9441  
export@vessel.co.jp

**VESSEL EUROPE S.A.R.L.**

8, avenue Johannes Gutenberg  
78310 Maurepas FRANCE

Tel : +33 (0)1 69 19 17 42 Fax : +33 (0)1 69 19 42 20  
info.vessel-europe@vessel.co.jp

[www.vessel.co.jp/english/](http://www.vessel.co.jp/english/)